

REV.	DESCRIPTION	BY	DATE
A	REVISED WRAP SEGMENTS COMPLETE WITH CH SPLIT		
	ADD ANOTHER ITEM ON THE BILL OF MATERIAL	MS	10-FEB-16
B	REVISED WRAP RING WIDTH FROM 18.50 TO 17.50	MS	17-FEB-16

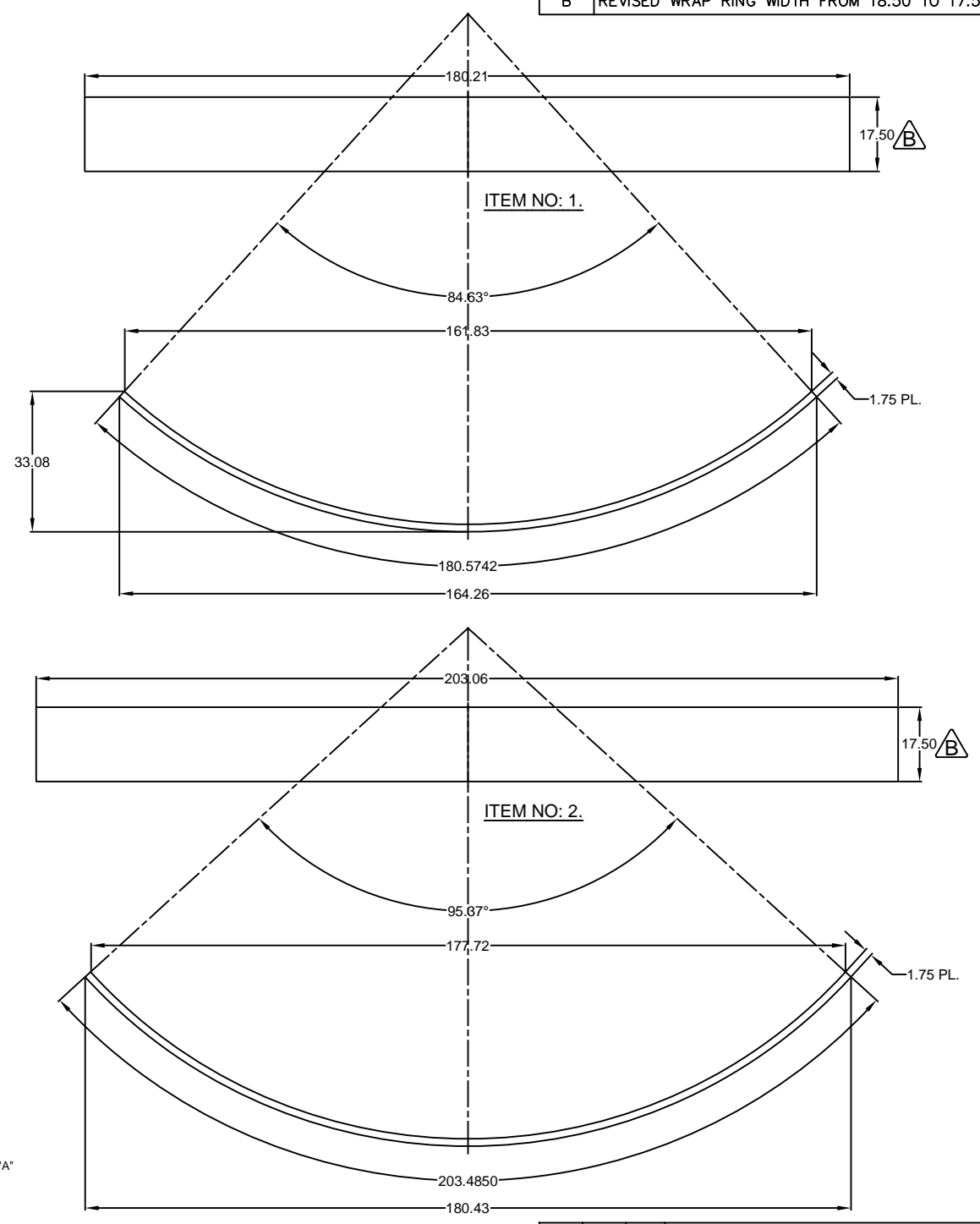
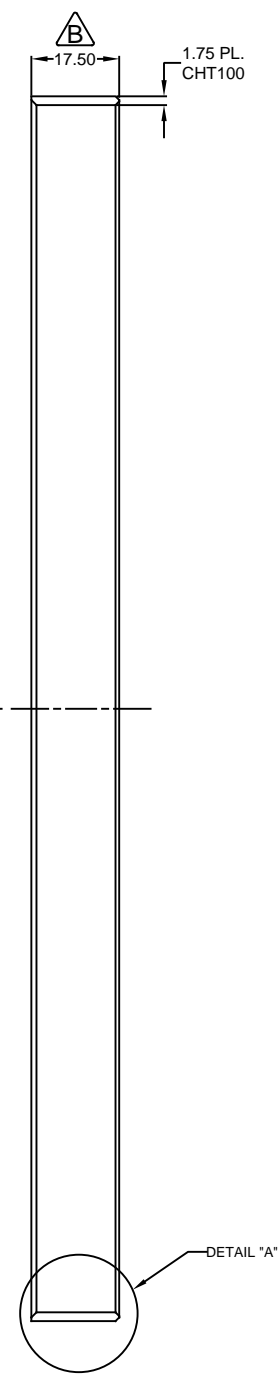
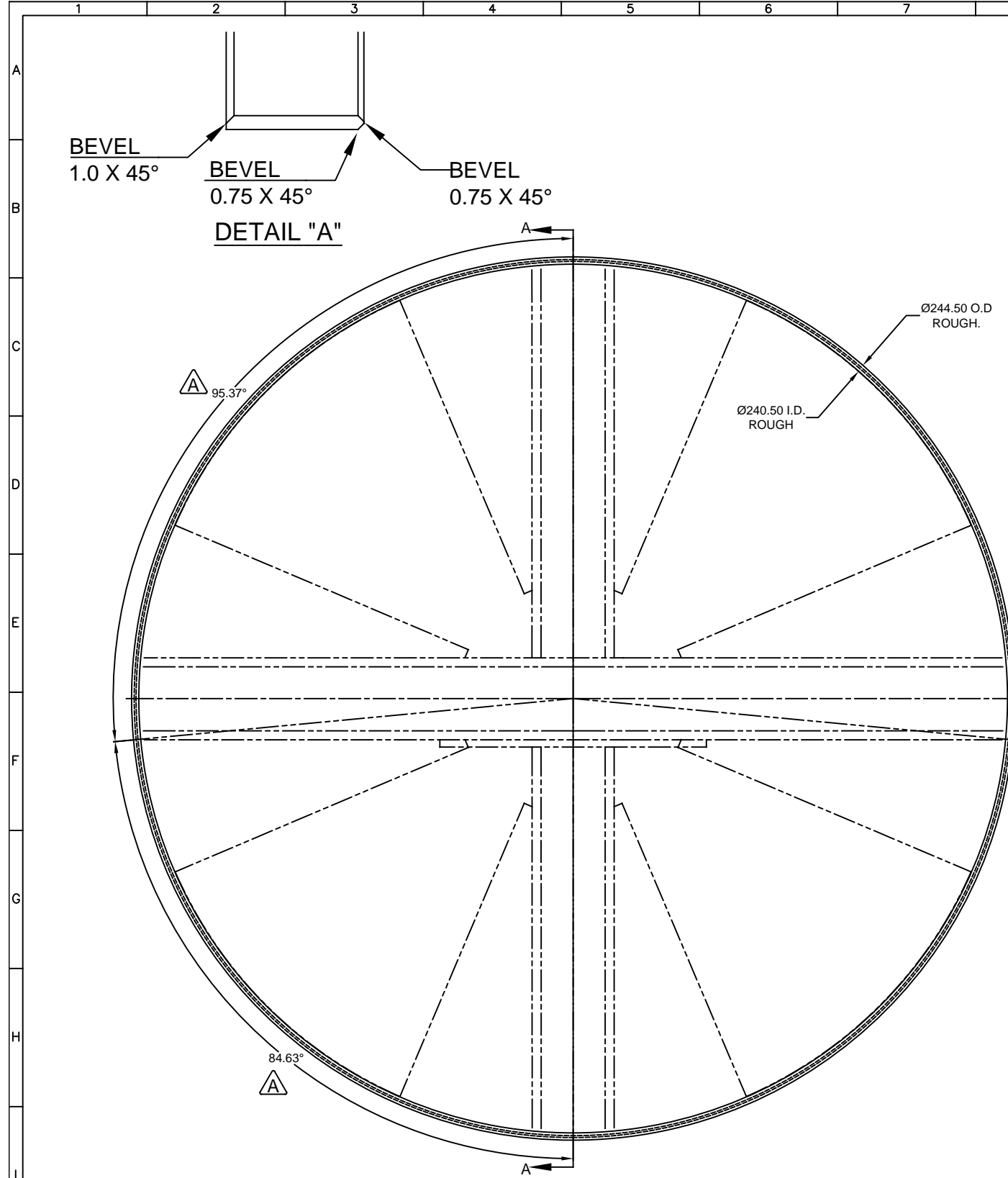

NOTE: SEGMENTS TO BE DEFINED BY PLATE AVAILABLE. USE MINIMUM NUMBER OF SEGMENTS.

ITEM NO.	QTY. (EA)	UDM	LENGTH/UNIT	AREA/UNIT	DESCRIPTION	PARTNUMBER	MATL DESCRIPTION	MATL NUMBER
2	2	SQ IN		3364		475117-T002	PLATE, 1.75, CSA Q100, HR	PLQ7011
1	2	SQ IN		3772		475117-T001	PLATE, 1.75, CSA Q100, HR	PLQ7011

Confidential	
MANUFACTURING NOTES:	
TOLERANCES	
2 DECIMAL ± 0.030	
3 DECIMAL ± 0.010	
ANGULAR ± 1°	
MACHINED SURFACES TO BE 125 √ UNLESS OTHERWISE SPECIFIED.	

ITEM	QTY	UOM	DESCRIPTION	PART No.
UNLESS SPECIFIED, ALL UNITS ARE:				
IMPERIAL: <input checked="" type="checkbox"/> (Inches) METRIC: <input type="checkbox"/> (MM)				
DESIGNED:	06-JAN-16	MVS	TITLE: CUTTINGHEAD WRAP RING ASS'Y WRAP RING WELDING PREPARATION AND WELDMENT ASSEMBLY	
DRAWN:	06-JAN-16	MVS	SCALE: NTS	
REVIEWED:	17 Feb 16	MVS	DRAWING NO.: 475117	
APPROVED:	17 Feb 16	KB	SHEET: REV: S01 B	
			DD-MMM-YY	BY

Lovsuns Tunneling Canada Ltd